

FLEETWOOD FOLDING TRAILERS, INC.
INSTALLATION INSTRUCTIONS

1968-607
January 2007

PART NUMBER: 4713-9021 – RSF/CSR FILON CORNER CAP REPLACEMENT
4713-9031 – RSR/CSF FILON CORNER CAP REPLACEMENT

This kit is for use on 2007 Evolution models.

This Kit Contains:

4"	-	4350000041	Butyl tape
1'	-	4350000047	Eternabond tape
1 ¼'	-	4350000084	Black Foam tape
1	-	4702C022	RSR/CSF Corner cap (4713-9031)
1	-	4702C023	RSF/CSR Corner cap (4713-9021)
2	-	4767-958	Black Tek screw
*	-	4768-142	Weld-On adhesive
*	-	4768-148	Weld-On dispenser gun
*	-	4768-149	Weld-On mixer tube

***NOTE:** Weld-On adhesive, dispenser gun and mixer tube need to be ordered through Fleetwood Folding Trailers Customer Service Department. There will be a \$50.00 deposit required when requesting the usage of the dispenser gun.

IMPORTANT NOTICE

These instructions are for the use of qualified individuals specifically trained and experienced in the installation of this type equipment and related system components. Installation and service personnel are required by some states to be licensed. Persons not qualified shall not attempt to install this equipment nor interpret these instructions.

INSTRUCTIONS:

1. Remove the 2 Tek screws located near the bottom of the corner cap.
2. Place a strip of duct tape along the top corner and bike rack track. See Figure 1.
3. Using a rotary tool with a cutoff wheel or a hacksaw, score a line in the corner cap. (Do not cut completely through the cap). Locate this cut line 1/8" from the end of the side bike rack track. Begin cutting at the edge, near the bike rack track and cut towards the canopy track. (Do not cut beyond the canopy track). See Figure 1.
4. Remove the corner cap by lifting along the bottom edge. The cap will break along the score line cut in Step 3.

NOTE: The portion of the cap that had not been cut in Step 3 will pull out from underneath the canopy track.

5. Measure approximately 1 ½" out from the end of the canopy track and cut the Eternabond sealant tape. The Eternabond will need removed from the bottom edge of the top up to this cut line. To remove the Eternabond, start at the bottom and roll the Eternabond towards the cut line. Clean the top surface with alcohol.
6. Remove the plastic covering from one side only of the new piece of Eternabond. Place the uncovered side against the top to cover the area exposed and cleaned in Step 5. Make sure the new piece of Eternabond is adhered to both filon sides of the top. See Figure 2. Firmly press the Eternabond into place assuring adhesion and sealing.
7. Trim off the excess Eternabond flush with the bottom edge of the top seal extrusions. See Figure 2.
8. Using a rotary tool with a cutoff wheel or a hacksaw, trim the remaining portion of the original top corner flush with the end of the canopy track. See Figure 3.

CAUTION: Do not cut into the top skin during this trim operation.

9. Apply a ¼" bead of clear silicone caulking along the perimeter of the Eternabond. It is important to assure a complete seal along the side and end seal extrusions. See Figure 3. Allow the silicone to setup before installing the new corner cap.
10. Using a rotary tool with a cutoff wheel or a hacksaw, remove the top flange of the corner cap. See Figure 4.
11. After the silicone has setup, "dry fit" the new corner cap on the top to check the fit. Make sure there is no exposed caulking or Eternabond visible when the cap is positioned.
12. Place a 1" piece of butyl tape on the inside of the corner cap covering each of the lower screw holes.
13. The Weld-On adhesive will be used to glue the top portion of the new corner cap.
14. Apply a bead of the Weld-On adhesive to the top next to the end of the canopy track. See Figure 5.

NOTE: Do not place the adhesive on the Eternabond sealant tape or the clear silicone caulking.

15. Place the corner cap on the top and press firmly into place. Make sure the lower screw holes in the corner cap align with the holes in the side and end seal extrusions. Apply duct tape as shown in Figure 6 to hold the corner cap in place while the Weld-On adhesive cures.

NOTE: The Weld-On adhesive requires approximately 30 minutes to cure. Do not remove the tape for at least 30 minutes.

16. Reattach the bottom of the corner cap with the Tek screws previously removed. Make sure the butyl tape is covering the screw holes.

FIGURE 1

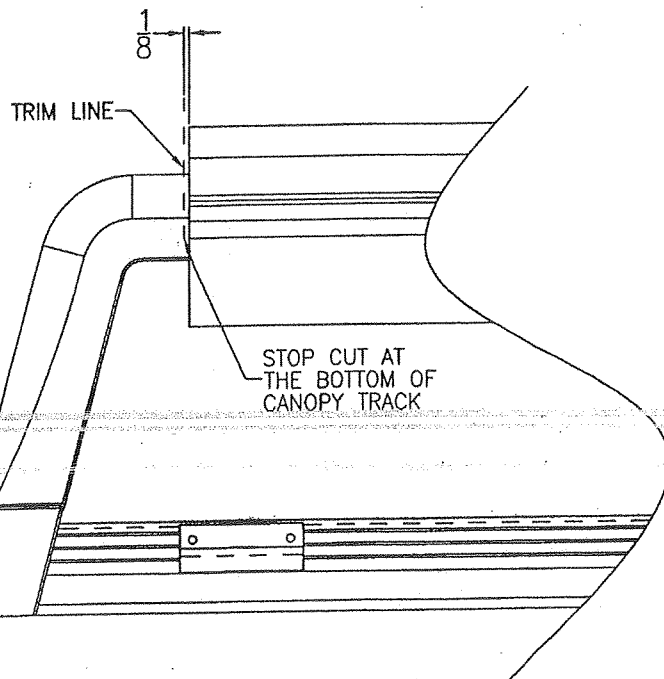
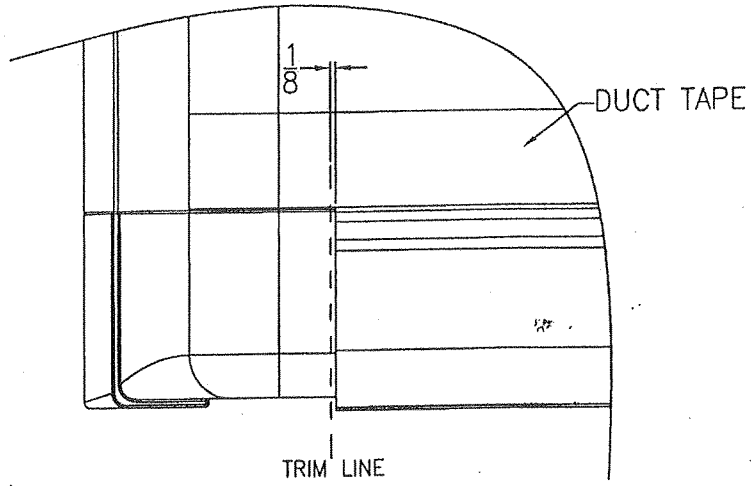

1968-014

FIGURE 2

DO NOT REMOVE ETERNABOND
TAPE IN THIS AREA

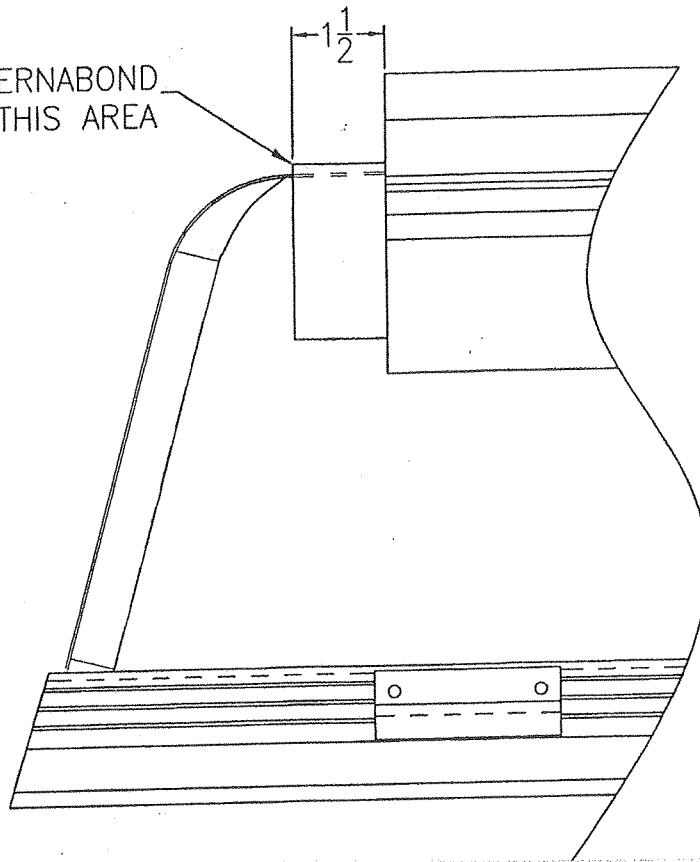

1968-014

FIGURE 3

TRIM REMAINING PORTION
OF THE END CAP HERE

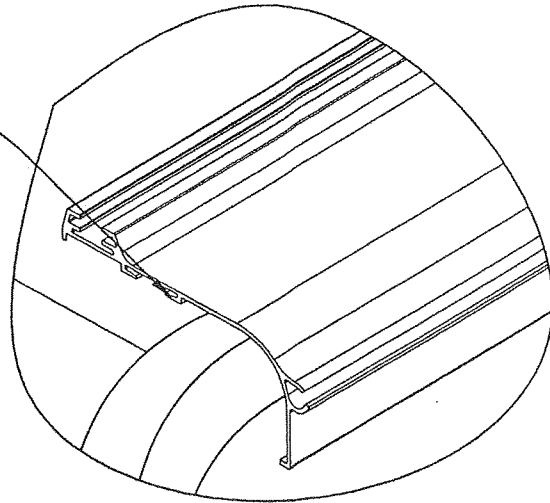
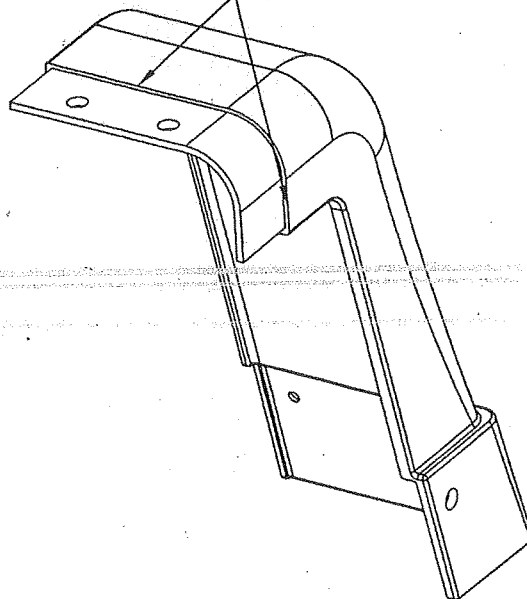

FIGURE 4

CUT LINE



1968-014

FIGURE 5

APPLY BEAD OF WELD-ON

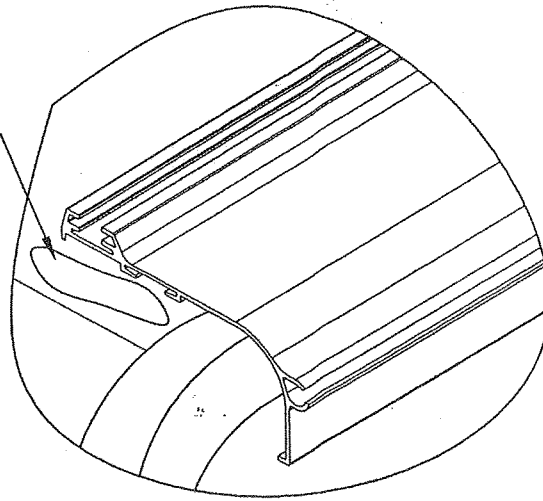
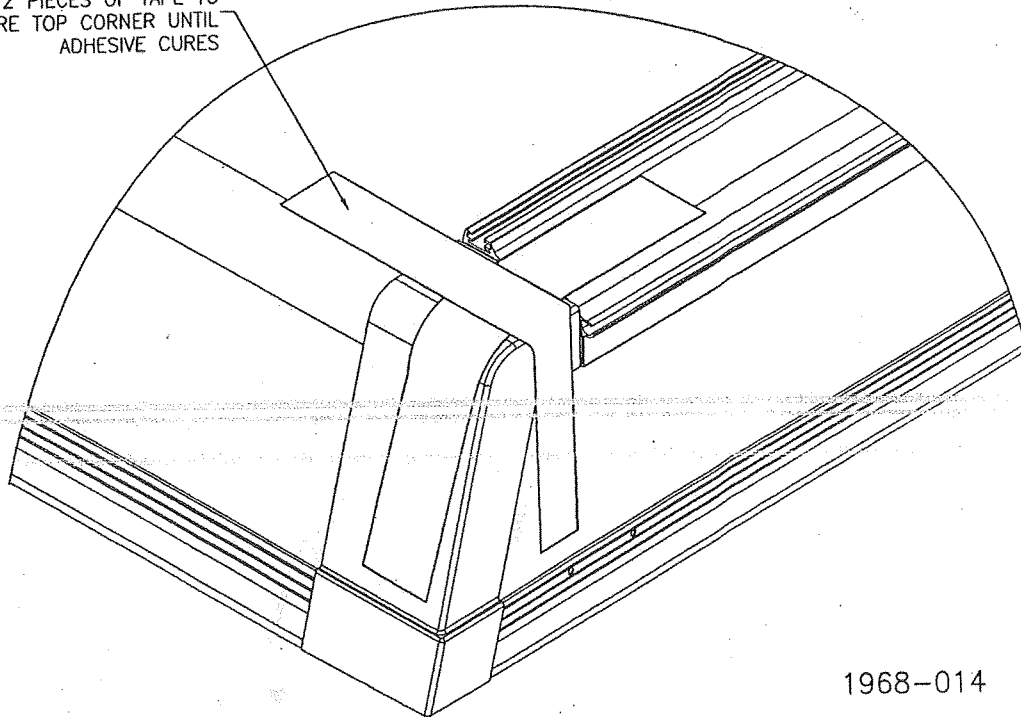

FIGURE 6

USE 2 PIECES OF TAPE TO
SECURE TOP CORNER UNTIL
ADHESIVE CURES



1968-014